

**Paradigma's
Emergentie
Organisatie principes
Comping en Jamming**

**Teun Hardjono
19 januari 2021**





EFQM®

QUALITY...

- **is meeting specifications**
(Feigenbaum)
- **is determined by the customer**
(Juran)
- **is no coincidence, but as a result of an intelligent effort**
(Ruskin/Deming)
- **is a subjective perception**
(Pirsig e.a.)



Meten is Weten

Valeo ClimTest+ en ClimService

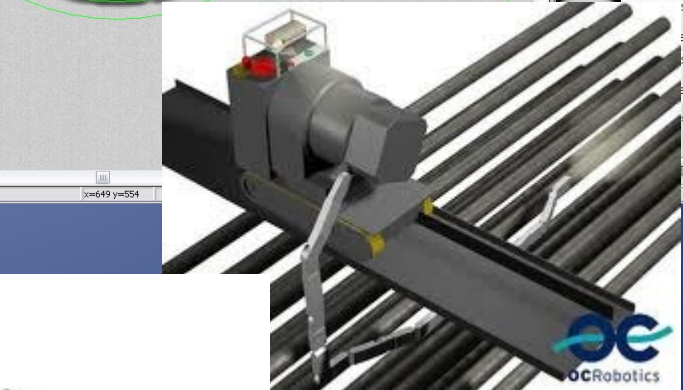
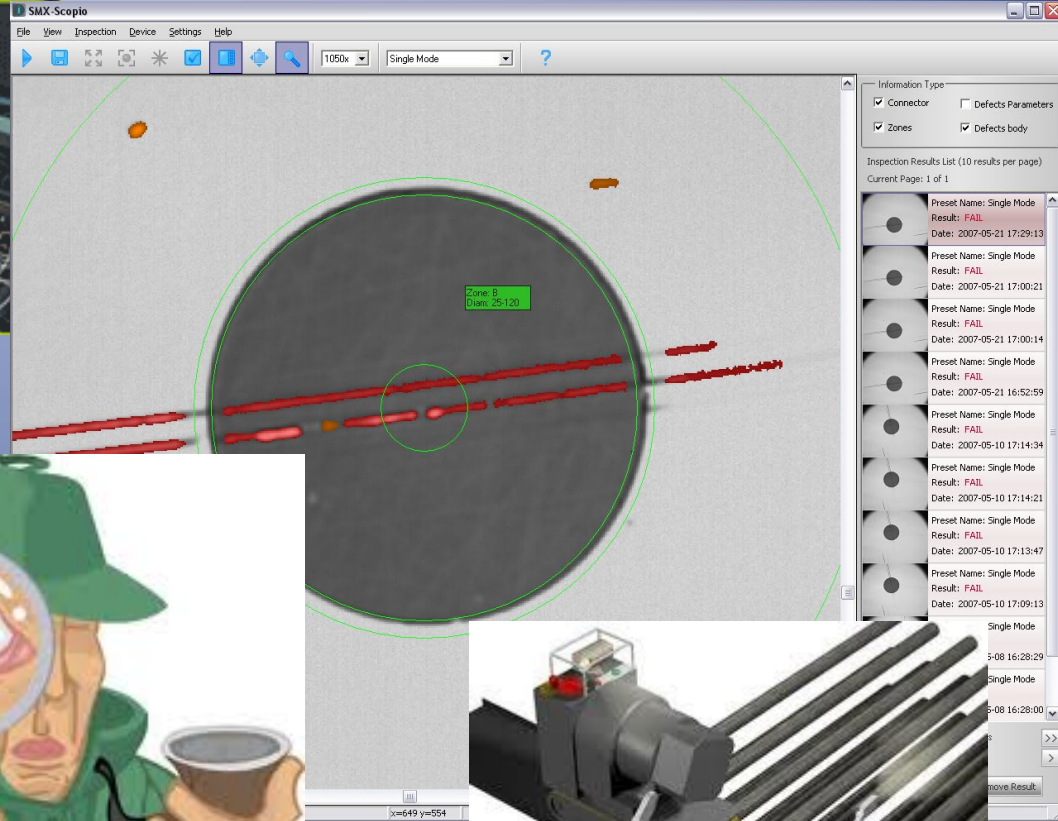

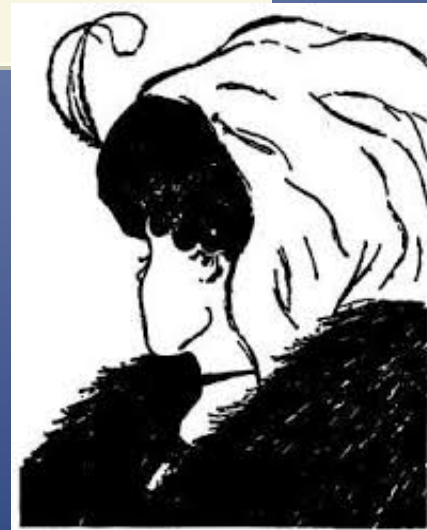

Incommensurabiliteit van paradigma's (Kuhn/ Essers)

- Het ontbreken van gemeenschappelijke of onpartijdige maatstaven
- ontkenning van theorie neutrale toegang tot de werkelijkheid
- de waarheid is afhankelijk van het conceptueel kader
- paradigma's zijn wederzijds onvertaalbaar en dus ook niet elkaars tegenpolen
- succesvolle communicatie ertussen wordt verhinderd en kennis is per saldo zelf legitimerend

Het empirie paradigma

empirical paradigm

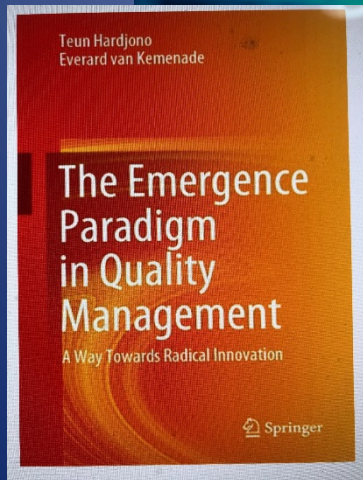

Het empirie paradigma

Quality is meeting specifications

Quality as a technical measurable fact often determined by experts

entiteit is een concreet object

Controle:

- specificaties
- testen
- inspectie
- steekproeven

- objectieve conclusies
- standaarden
- criteria
- product certificatie

De kwaliteitskundige



Dr. Kaoru Ishikawa

(1915 - 1989)

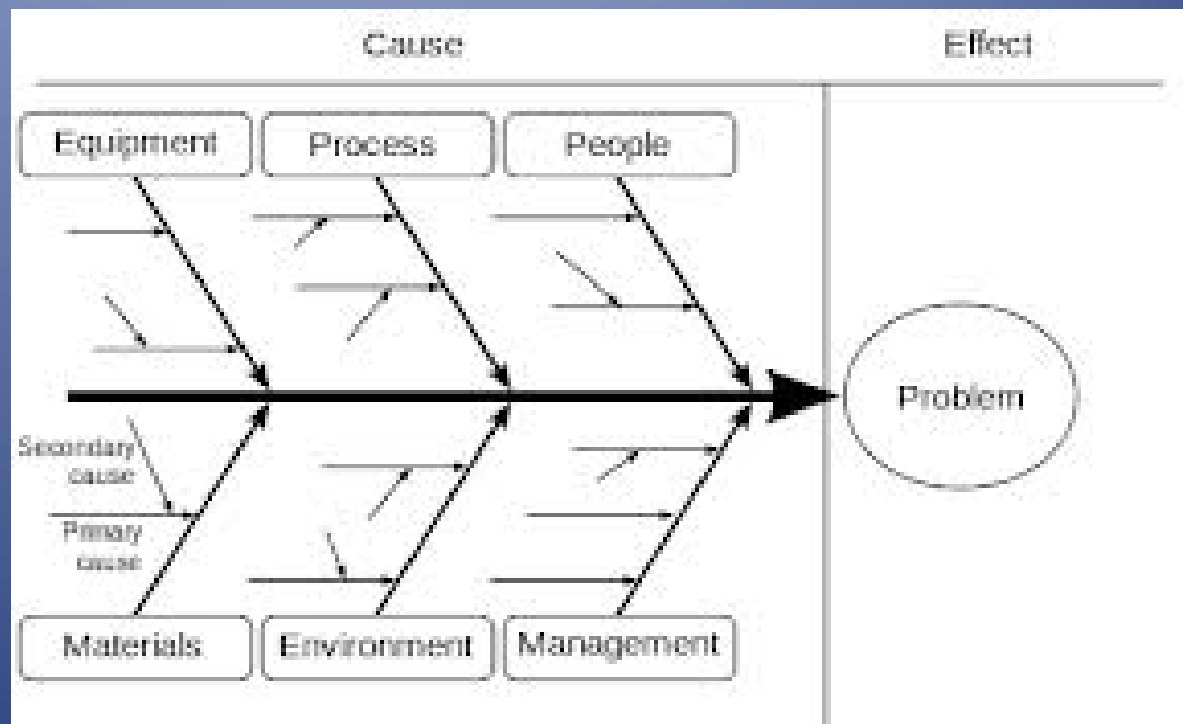

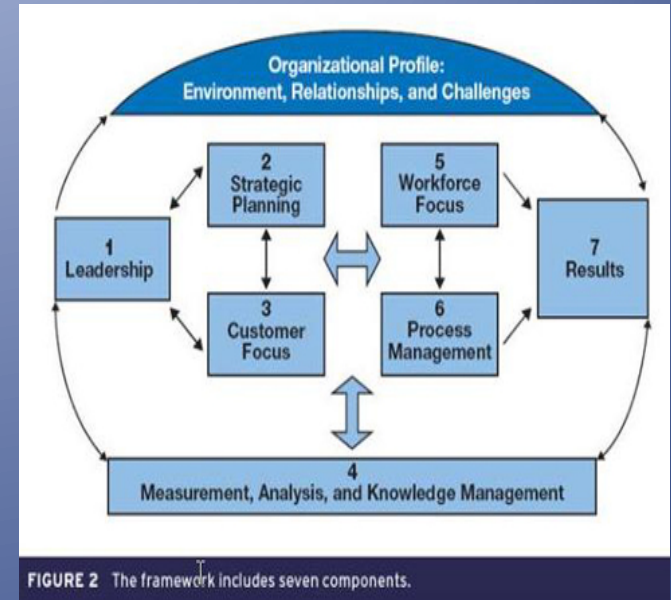
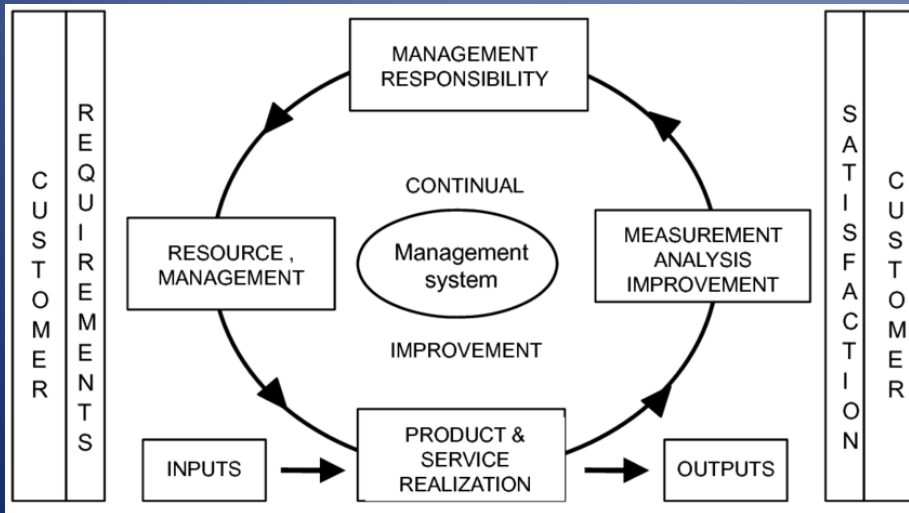

FIGURE 2 The framework includes seven components.



Het referentie paradigma

Quality is determined by the customers ()

Quality is an idea of group how a construct should look like or perform

**De entiteit is een construct
(bv een organisatie)**

Continuous improvement:

- quality circles
 - kai zen
 - spc/six sigma
 - plan-do-check-act
-
- inter subjectieve conclusies
 - modellen (EFQM, MBQA)
 - systeem certificatie ISO 9000)
 - aandachtsgebieden

Het referentie paradigma

reference paradigm

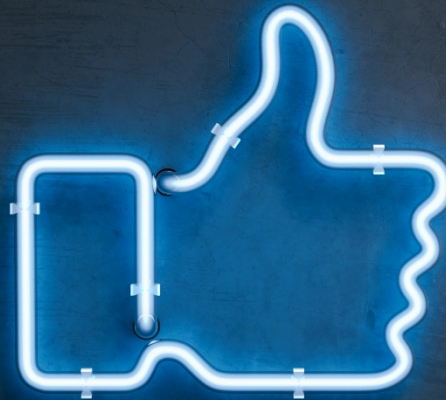

made with
shutterstock editor

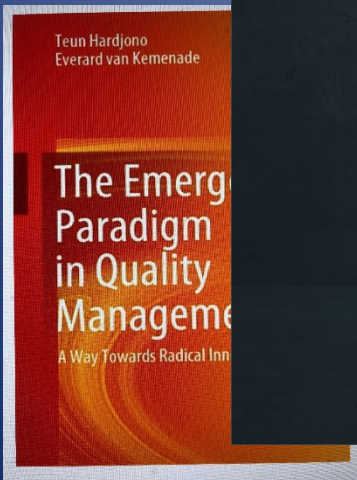

De organisatie adviseur





Zen and the art of motorcycle maintenance (Lila)

Robert M. Pirsig

reaching the essence
terug naar de bedoeling



Het reflectief paradigma

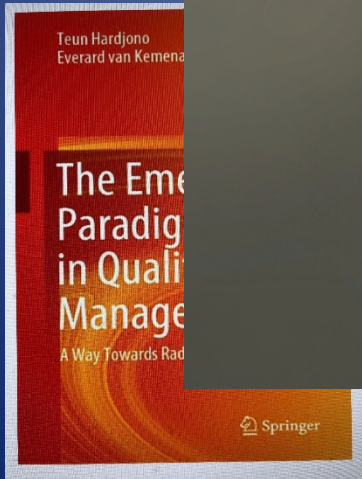

Het reflectief paradigma

Quality is a subjective perception (Pirsig e.a.)

Quality is an positive experience

entiteit is een concept (liefde, geluk, geloof, dienst)

Reaching the essence

- spiritualiteit
- Dilemma's
- Onzekerheid
- waarde/verantwoordelijkheid

- concept
- tot de kern komen
- filosofische scholen
- ethiek en schoonheid

De filosoof

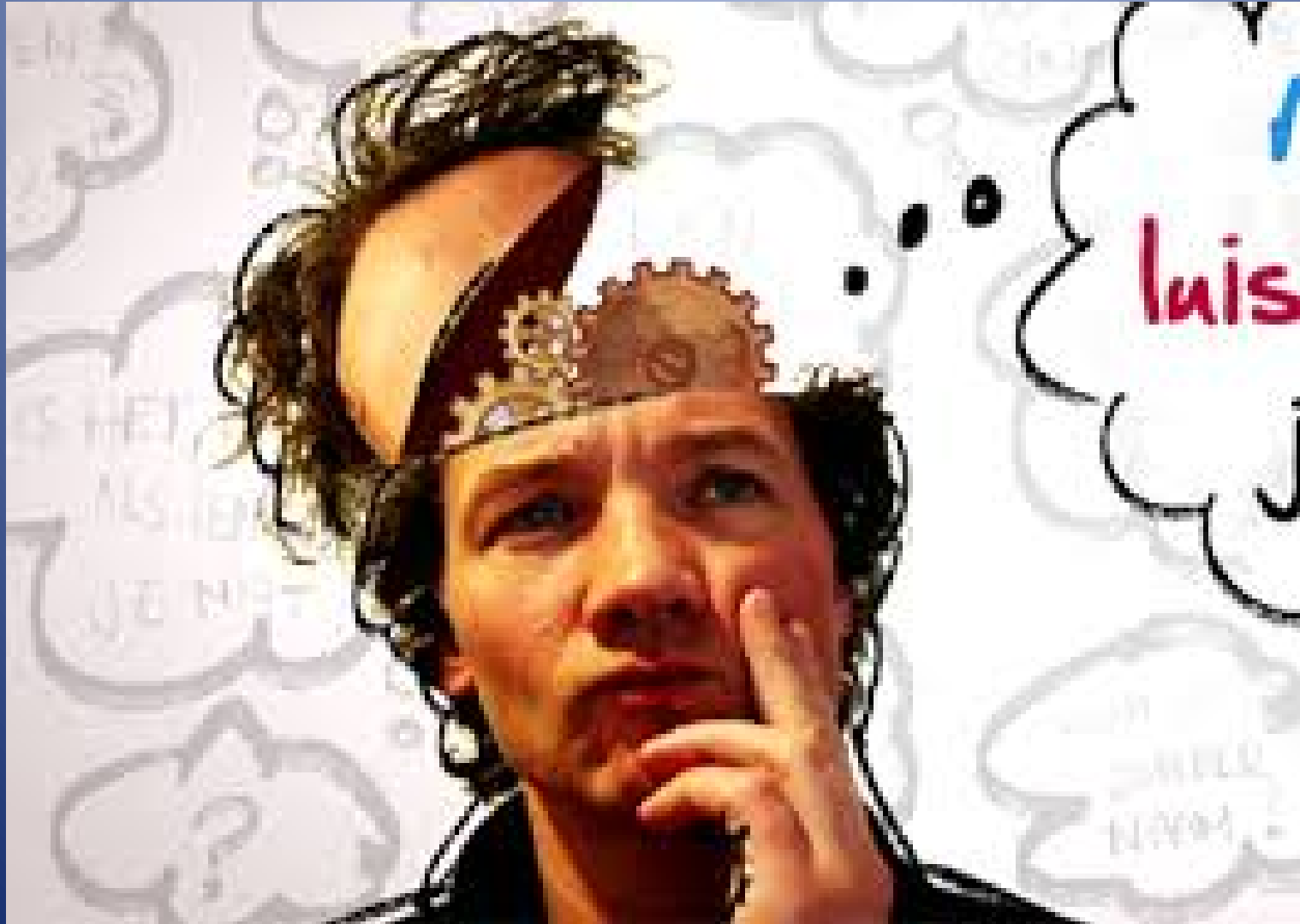



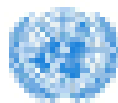

SUSTAINABLE DEVELOPMENT GOALS

1 NO POVERTY

2 ZERO HUNGER

3 GOOD HEALTH AND WELL-BEING

4 QUALITY EDUCATION

5 GENDER EQUALITY

6 CLEAN WATER AND SANITATION

7 AFFORDABLE AND CLEAN ENERGY

8 DECENT WORK AND ECONOMIC GROWTH

9 INDUSTRY, INNOVATION AND INFRASTRUCTURE

10 REDUCE INEQUALITIES

11 SUSTAINABLE CITIES AND COMMUNITIES

12 RESPONSIBLE CONSUMPTION AND PRODUCTION

13 CLIMATE ACTION

14 LIFE BELOW WATER

15 LIFE ON LAND

16 PEACE, JUSTICE AND STRONG INSTITUTIONS

17 PARTNERSHIPS FOR GOALS

SUSTAINABLE DEVELOPMENT GOALS

William Edwards *Deming*

Sioux City (Iowa), 14 October 1900 - Washington D.C., 20 December 1993



1. *Create constancy of purpose for improving products and services.*
2. *Adopt the new philosophy.*
3. *Cease dependence on inspection to achieve quality.*
4. *End the practice of awarding business on price alone; instead, minimize total cost by working with a single supplier.*
5. *Improve constantly and forever every process for planning, production and service.*
6. *Institute training on the job.*
7. *Adopt and institute leadership.*
8. *Drive out fear.*
9. *Break down barriers between staff areas.*
10. *Eliminate slogans, exhortations and targets for the workforce.*
11. *Eliminate numerical quotas for the workforce and numerical goals for management.*
12. *Remove barriers that rob people of pride of workmanship, and eliminate the annual rating or merit system.*
13. *Institute a vigorous program of education and self-improvement for everyone.*
14. *Put everybody in the company to work accomplishing the transformation.*

Het emergentie paradigma



Features of pragmatism (emergentie)

J. Dewey/S Takkema

- **Holistic**
- **Reject contradictions**
- **Intelligent inquiry**
- **Temporality**
- **Presumption of variability**
- **Pluralistic methods**
- **Primate for the practice**



Het emergentie paradigma

Quality is no coincidence, but a result of an intelligent effort (Ruskin)

Quality is an inter subjective perception taken the context

entiteit is een vraagstuk/probleem

Breakthrough:

- paradoxen
- discontinuïteiten
- complexiteit
- tijd (chronos & kairos)

- complexe vraagstukken
- kontekst afhankelijk
- jurisprudentie (experts)
- inter subjectief

de initiator/moreel leiderschap

LAUDATO SI'

ON CARE FOR
OUR COMMON HOME



POPE FRANCIS



ENCYCLICAL LETTER

“

In the face of the emergencies of human-induced climate change, social exclusion, & extreme poverty, we join together to declare that:

Human-induced climate change is a **scientific reality**, and its decisive mitigation is a **moral and religious imperative** for humanity.

”

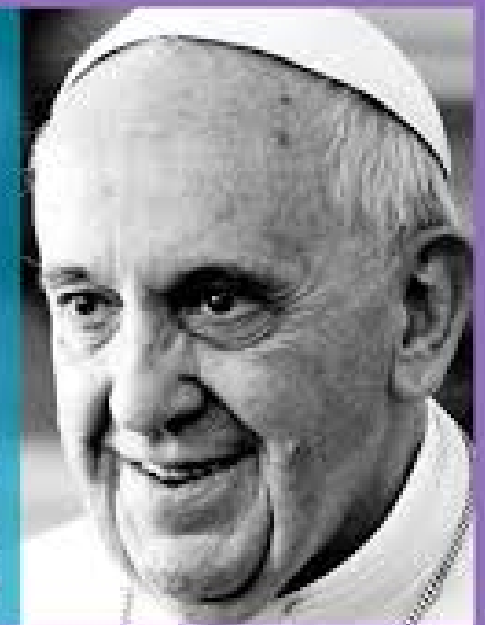

nieuwe organisatieprincipes



**The Best Jam
I've Ever Witnessed**

Part 2 of 6

nieuwe organisatieprincipes

mentaal model:

- Onderlinge afhankelijkheid
- Intimiteit

(inclusief denken)

(geborgenheid en respect)



nieuwe organisatieprincipes

mentaal model:

- **Afhankelijk** (inclusief denken)
- **Intiem** (geborgenheid en respect)

basis voor samenwerken:

- **Vertrouwen** (uitgaan van vakvolwassenheid)
- **open informatie** (communiceren)

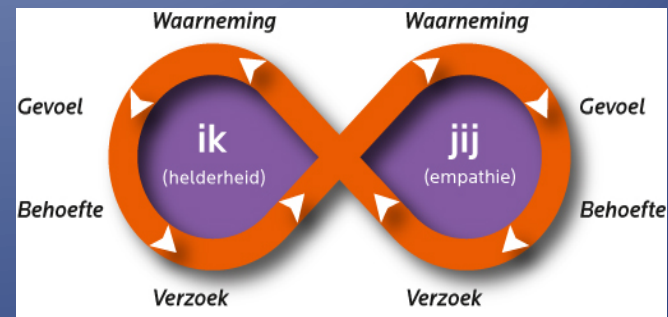

nieuwe organisatieprincipes

mentaal model:

- **Afhankelijk**
- **Intiem**

(inclusief denken)
(geborgenheid en respect)

samenwerken:

- **Vertrouwen**
- **Informer**

(uitgaan van vakvolwassenheid)
(communiceren)

constructie

- **Veilig**
- **Ruimtelijk**

(beschadiging voorkomen)
(accepteren variatie en variantie)

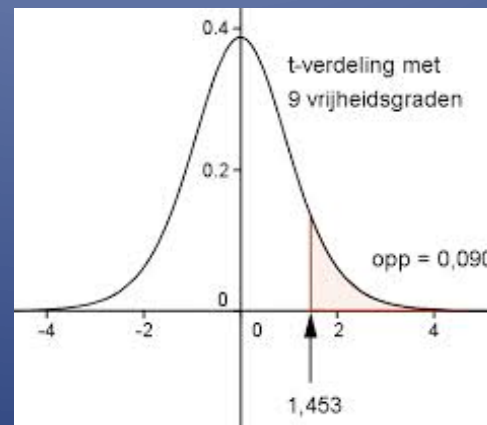

nieuwe organisatieprincipes

➤ **Afhankelijk**

(inclusief denken)

➤ **Intiem**

(geborgenheid en respect)

samenwerken:

➤ **Vertrouwen**

(uitgaan van vakvolwassenheid)

➤ **Informer**

(communiceren)

construeren:

➤ **Veilig**

(beschadiging voorkomen)

➤ **Ruimtelijk**

(accepteren variatie en variantie)

Besturen:

➤ **Verantwoordelijkheid**

(transparant zijn)

➤ **Aansprakelijkheid**

(voorkomen van verspilling)



Jamming en comping



Een succesvol 2021 gewenst

Tot ziens op het Winteramp 2022